



ALLEN & SHEPPARD.



2A Wilga Street WEST PENNANT HILLS NSW

3 2 2

Are you looking for an independent, single story 3 bedroom, 2 bathroom and 2 car accommodation low maintenance home? This could be the one. Situated next to a public reserve and park and so close to bus stops to train and city, near shops and primary school, this true single level 20 year old home would be ideal as a downsizer, first home or investment. The well maintained brick and tile property features a large covered outdoor entertaining area running along the entire rear of the home that looks out over the manageable rear lawn and garden. All 3 bedrooms have built-in robes, with an ensuite to the main. There is a single lock-up garage and oversized single carport, an air conditioner in the family/kitchen area and, being situated down a private near-level driveway, there is a nice sense of privacy.

Properties like this do not come along very often and will not last long. Call to inspect today.

Price : \$ 675,000

View : <https://www.allenandsheppard.com.au/sale/nsw/hills/west-pennant-hills/residential/house/620442>
2



James Sheppard
02 9481 9000

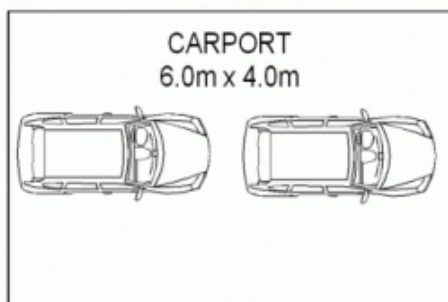
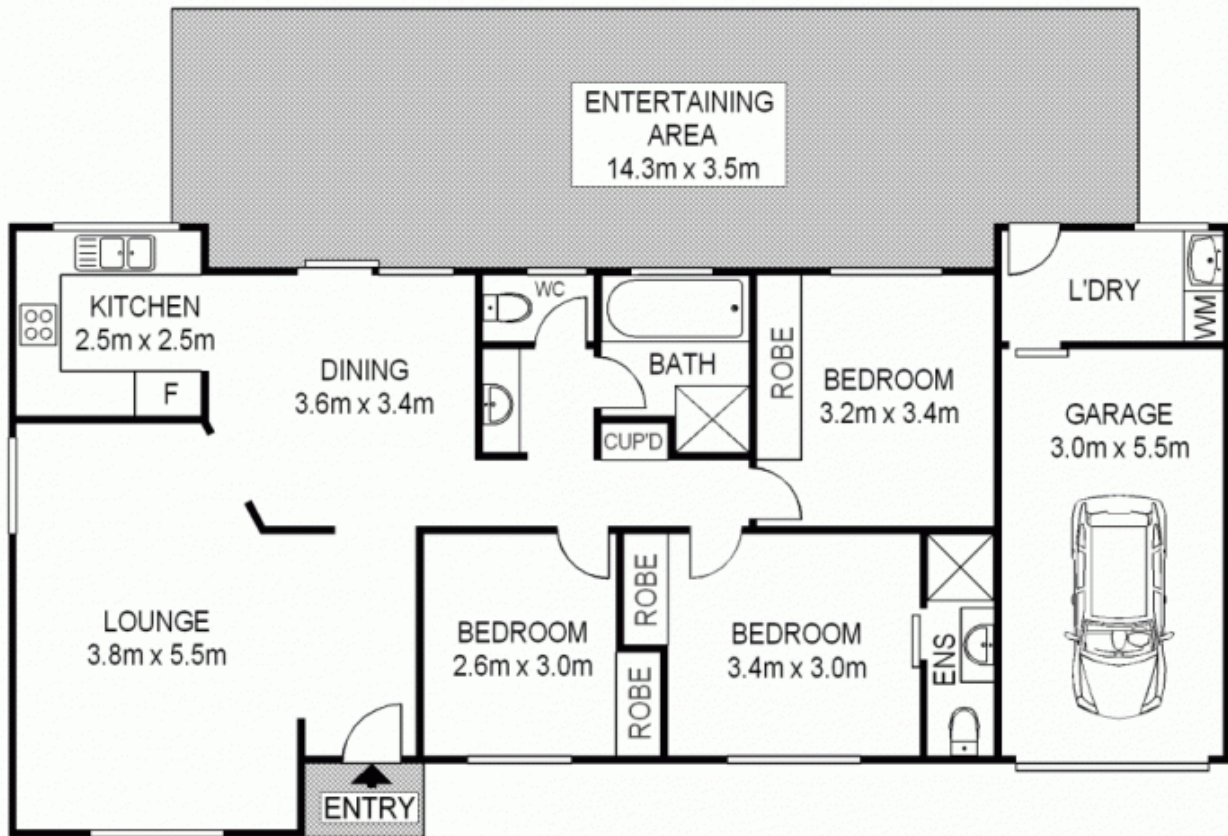

Scale shown in metres. All dimensions herein are approximate and gathered from sources believed to be reliable. Whilst every effort is made for the accuracy of our floor plans, interested parties should rely on their own enquires. Floor Plans by Industrie Media | industriemedia.tv

S1

2A Wilga Street, West Pennant Hills

